

RESOL DeltaSol[®] BS Pro

Mounting
Connection
Handling
Fault localization
Examples



Thanks for buying a RESOL.
Read this manual carefully to get the best performance from this unit.

DeltaSol[®] BS Pro

Contents

Imprint	2	2.1	Adjustment buttons	10
Security devices	2	2.2	System monitoring display	10
Technical data and function survey	3	2.2.1	Channel indication	10
1. Installation	4	2.2.2	Tool bar	10
1.1 Mounting	4	2.2.3	System screen	11
1.2 Electrical wiring	4	2.3	Blinking codes	11
1.2.1 Standard solar system	5	2.3.1	System screen blinking codes	11
1.2.2 Solar system and heat exchange	5	2.3.2	LED blinking codes	11
1.2.3 Solar system and after-heating	6	3. Commissioning	12	
1.2.4 Solar system and store charge in layers	6	4. Control parameter and indication channels ...	13	
1.2.5 2-store-solar-system valve logic	7	4.1 Channel overview	13	
1.2.6 2-store-solar-system pump logic	7	4.1.1-5 Indication channels	15	
1.2.7 Solar system with 2 collectors	8	4.1.6-21 Adjustment channels	16	
1.2.8 Solar system with after-heating by solid fuel boiler	8	5. Tips for fault localization	21	
1.2.9 Solar system with heating circuit reverse raising	9	5.1 Miscellaneous	22	
2. Operation and function	10	6. Accessory	24	

Safety regulations:

Please read the following information carefully before installing and operating the controller. In this way damage to the solar system by wrong installation will be avoided. Please observe that the mounting is adapted to the characteristics of the building, that the local regulations are respected and is conform with the technical rules.

DIN 4757, part 1

Solar heating systems with water and water mixtures as heat transfer medium; Demands to the safety realization.

DIN 4757, part 2

Solar heating systems with organic heat transfer medium; Demands to safety realization.

DIN 4757, part 3

Solar heating systems; solar collectors; Meanings; safety regulations; Testing of standstill temperature

DIN 4757, part 4

Solar thermal systems; solar collectors; determination of efficiency, heat capacity and pressure loss.

In addition to that European standards are worked out:

PrEN 12975-1

Thermal solar systems and their components; collectors, part 1: General demands.

PrEN 12975-2

Thermal solar systems and their components; collectors; part 2: Test processes

PrEN 12976-1

Thermal solar systems and their components; prefabricated systems, part 1: General demands.

PrEN 12976-2

Thermal solar systems and their components; prefabricated systems, part 2: Test processes

PrEN 12977-1

Thermal solar systems and their components; Customer-designed manufactured systems, part 1: General demands.

PrEN 12977-2

Thermal solar systems and their components; Customer-designed manufactured systems, part 2: Test processes

PrEN 12977-3

Thermal solar systems and their components; Customer-designed manufactured systems, part 3: Performance test of warm water stores.

Imprint

This mounting- and operation manual including all parts is copyrighted. Another use outside the copyright requires the approval of RESOL - Elektronische Regelungen GmbH. This especially applies for copies, translations, micro films and the storage into electronic systems.

Editor: RESOL - Elektronische Regelungen GmbH

Important notice:

We took a lot of care over the texts and drawings of this manual and to the best of our knowledge and consent. As faults can never be excluded, please note: Your own calculations and plans under consideration of the current norms and DIN-directions should only be basis for your projects. We don't offer a guarantee for the completeness of the drawings and texts of this manual - they only represent some examples. They can only be used on own risk. No liability is assumed for incorrect, incomplete or false information and the resulting damages.

Errors and technical changes excepted.

- System-monitoring-display
- Up to 4 temperature sensors Pt1000
- 2 semi-conductor relays for pump speed control
- 9 basic systems selectable
- Heat balancing
- Function control
- User-friendly operation by simple handling
- Housing in outstanding design and compact dimensions, easy to install

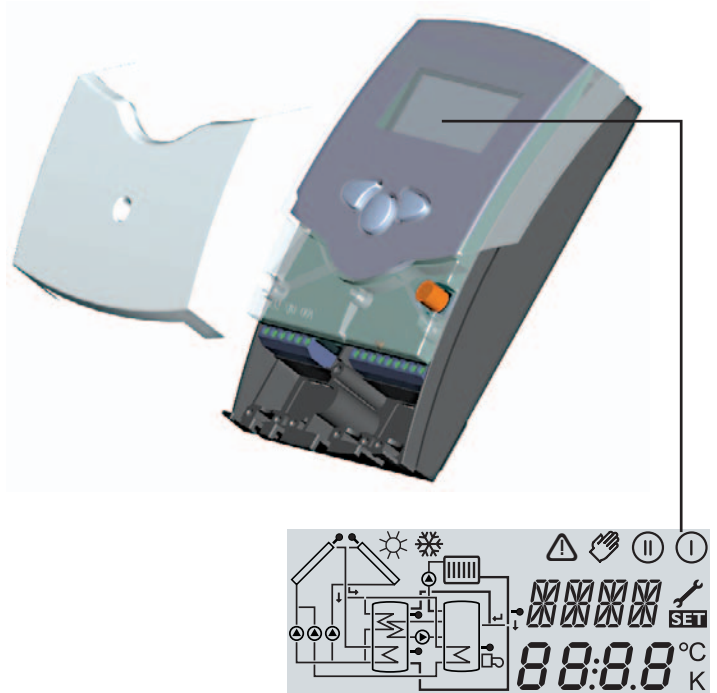

Scope of delivery:

1 x DeltaSol® BS Pro

1 x accessory bag

- 1 x spare fuse T4A
- 2 x screws and dowels
- 4 x strain relief and screws
- 1 x condenser 4,7 nF

Additionally enclosed in the full kit:

- 2 x sensor FKP6
- 2 x sensor FRP6

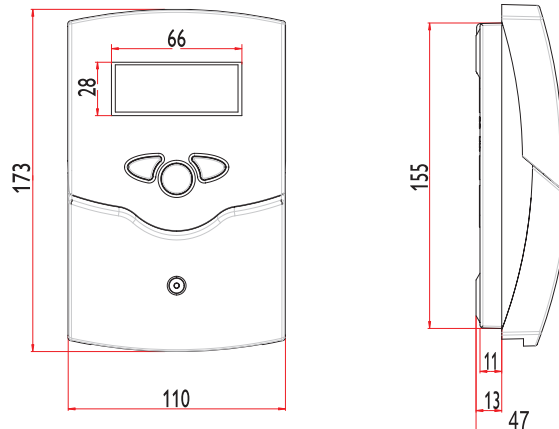

Technical data

Housing:

plastic, PC-ABS and PMMA

Protection type: IP 20 / DIN 40050

Environmental temp.: 0 ... 40 °C

Size: 172 x 110 x 46 mm

Mounting: wall mounting, mounting into patch-panels is possible

Display: System screen for system visualisation, 16-segment display, 7-segment display, 8 symbols for system status and operating control lamp

Operation: by 3 pushbuttons in the front of the housing

Functions: Differential temperature controller with optionally add-on system functions. Function control according to BAW-guidelines, operating hours counter for solar pump, tube collector special function, pump speed control and heat quantity balancing.

Inputs: for 4 temperature sensors Pt1000

Outputs: 2 semi-conductor relays

Power supply:

210 ... 250 V~

Total power supply:

4 (2) A 250 V~

1. Installation

1.1 Mounting

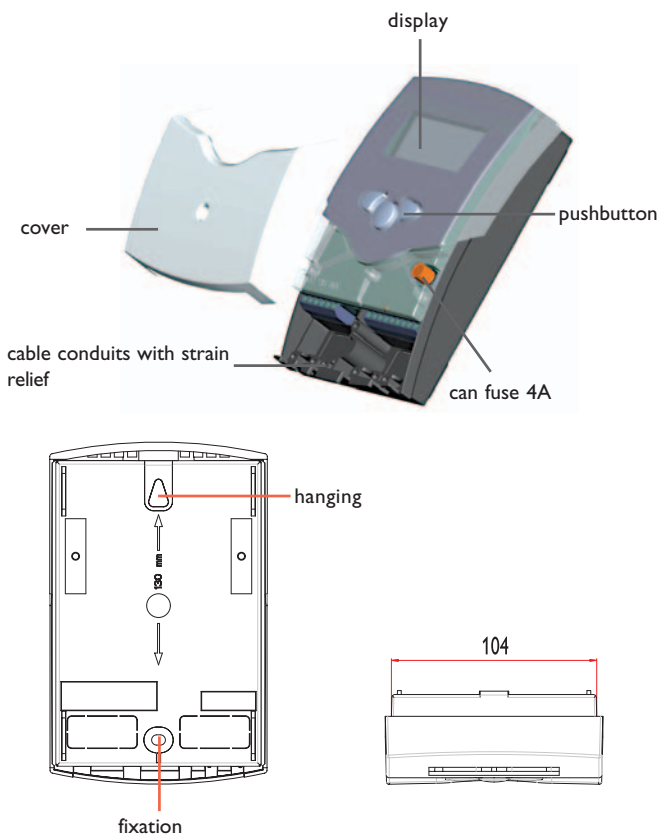

Warning!
Switch-off power supply before opening the housing.

The unit must only be located internally. It is not suitable for installation in hazardous locations and should not be sited near to any electromagnetic field. The controller must additionally be equipped with an all-polar gap of at least 3 mm or with a gap according to the valid installation regulations, e.g. LS-switches or fuses. Please pay attention to a separate laying of the cable lines and installation of ac power supply.

1. Unscrew the cross-recessed screw of the cover and remove it from the housing.
2. Mark the upper fastening point on the underground and pre-mount the enclosed dowel and screw.
3. Hang up the housing at the upper fastening point and mark the lower fastening point on the underground (hole pitch 130 mm), afterwards put the lower dowel.
4. Fasten the housing at the underground.

1.2 Electrical wiring

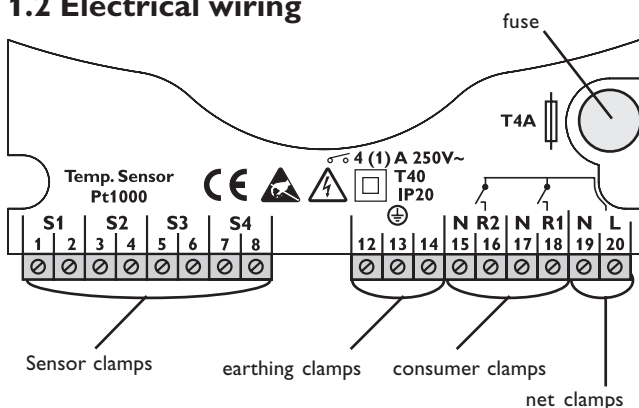

The power supply to the controller must only be made by an external power supply switch (last step of installation!) and the line voltage must be 210 ... 250 Volt (50...60 Hz). Flexible lines are to be fixed at the housing by enclosed strain relief supports and screws.

The controller is equipped with 2 standard relays, to which the **consumers** e.g. pumps, valves etc. can be connected:

- Relay 1
18 = conductor R1
17 = neutral conductor N
13 = ground clamp
- Relay 2
16 = conductor R2
15 = neutral conductor N
14 = ground clamp

The **temperature sensors** (S1 up to S4) will be connected to the following terminals independently of the polarity:

- 1 / 2 = Sensor 1 (e.g. Sensor collector 1)
- 3 / 4 = Sensor 2 (e.g. Sensor store 1)
- 5 / 6 = Sensor 3 (e.g. Sensor collector 2)
- 7 / 8 = Sensor 4 (e.g. Sensor store 2)

The **power supply** is effected to the clamps:

- 19 = neutral conductor N
- 20 = conductor L
- 12 = ground clamp (⊕)

Please note:

The relays are semi-conductor-relays for pump speed control - they need a minimum load of 20 W (power consumption of the consumer) for faultless function. When connecting auxiliary relays, motor valves, etc. are individually to the condenser which is enclosed in the mounting material, must be connected parallelly to the relevant relay output. Attention: for connection of auxiliary relays or valves, the minimum pump speed must be adjusted to 100 %.



Dangerous voltage on contact!



Electrostatic discharge can lead to damages of electronic components!

1.2.1 Allocation of clamps for system 1

Standard solar system with 1 store, 1 pump and 3 sensors. The sensor S4 / TRF can optionally be used for heat quantity balancing.

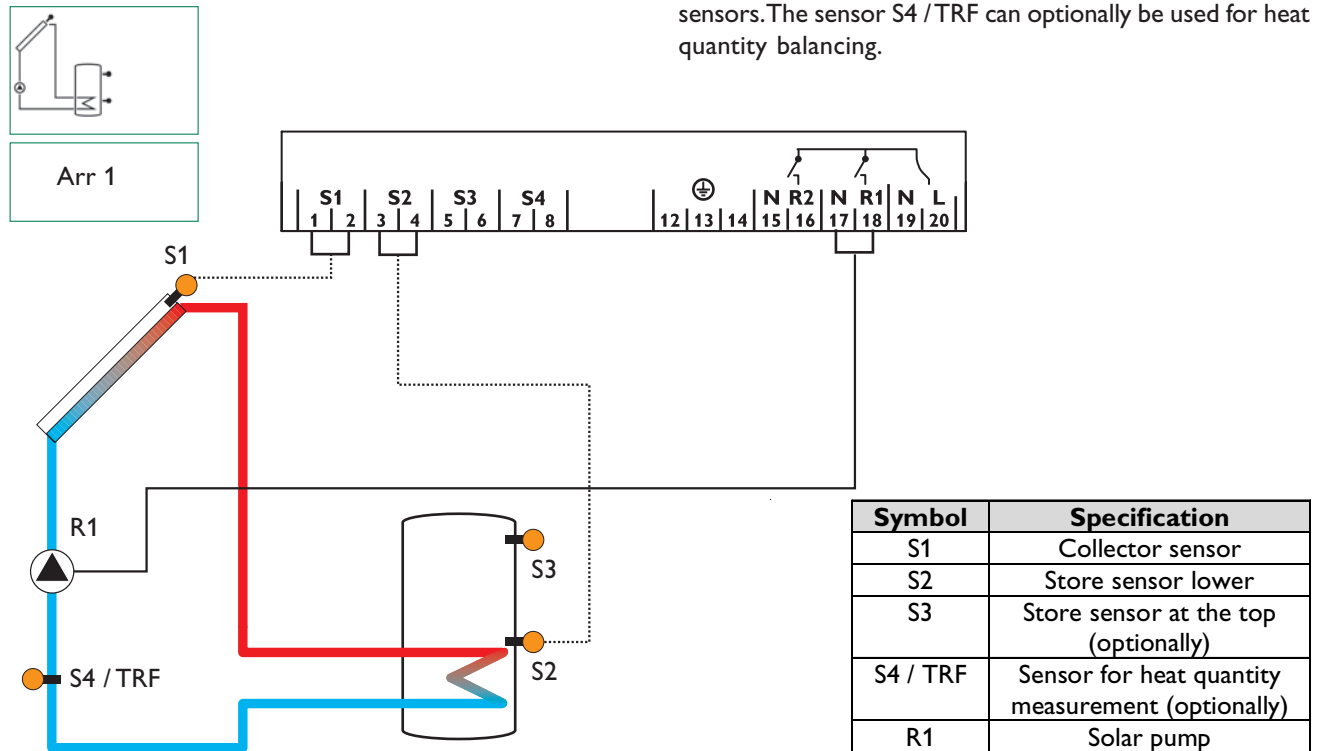

1.2.2 Allocation of clamps for system 2

Solar system and heat exchange of existing store with 1 store, 4 sensors and 2 pumps.

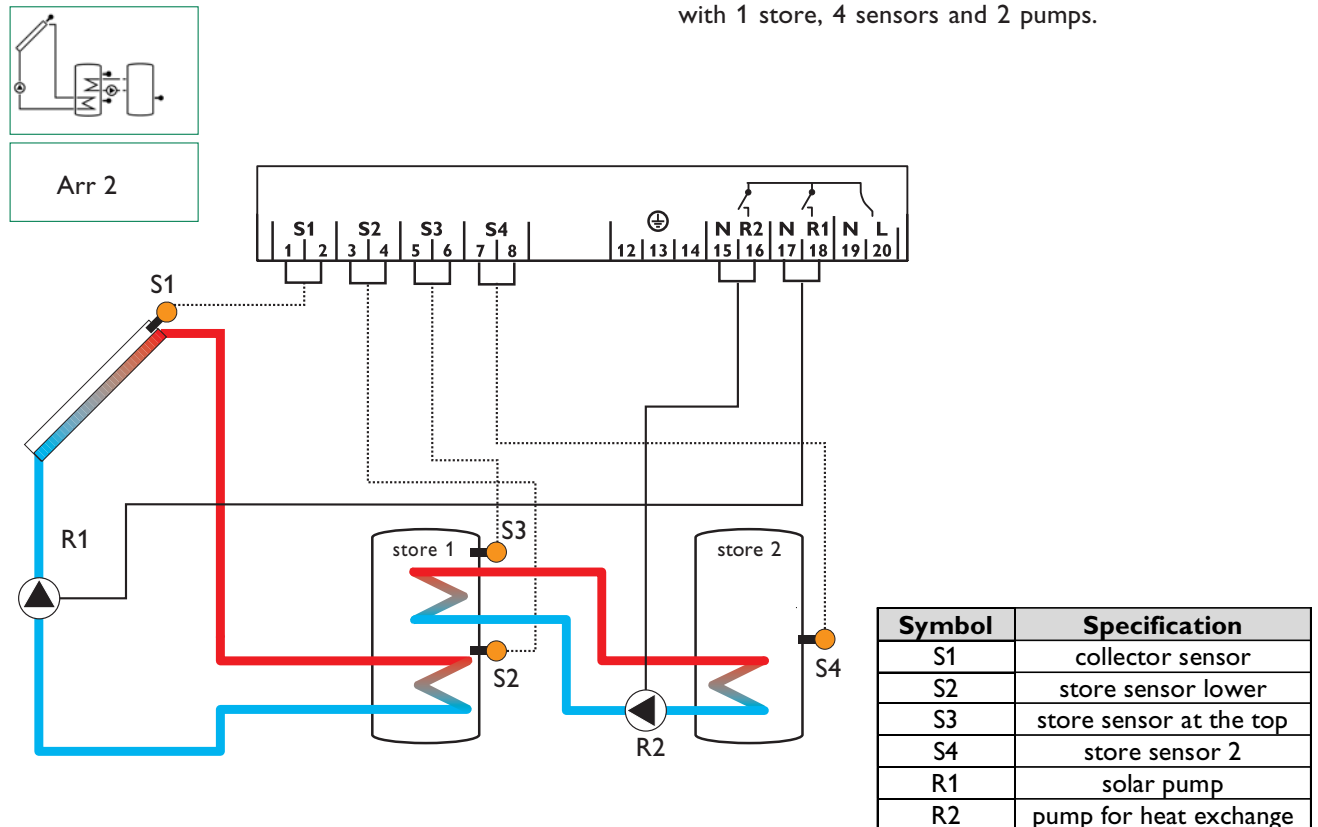

1.2.3 Allocation of clamps for system 3

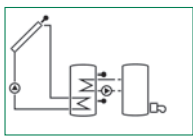

Arr 3

Solar system and after-heating with 1 store, 3 sensors and after-heating. The sensor S4 / TRF can optionally be used for heat quantity balancing.

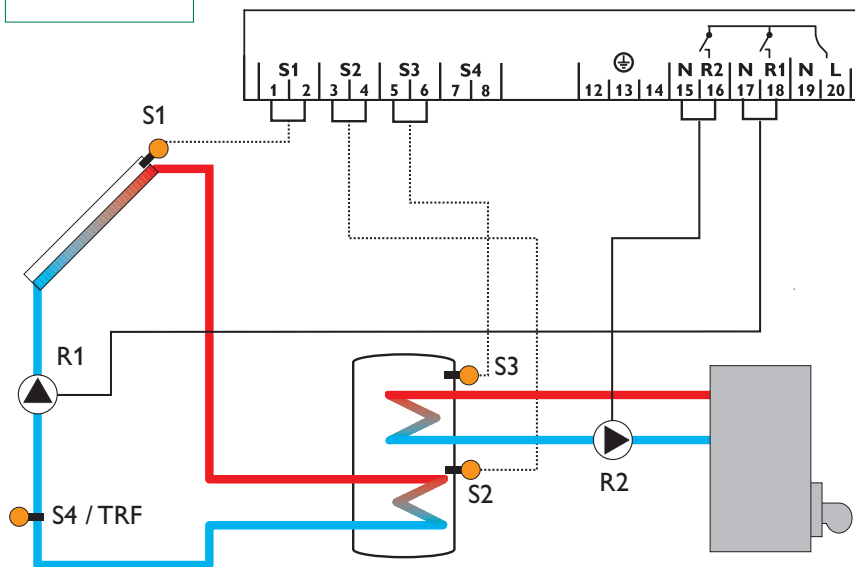

Symbol	Specification
S1	collector sensor
S2	store sensor lower
S3	store sensor at the top
S4 / TRF	sensor for heat quantity balancing (optionally)
R1	solr pump
R2	pump for heat exchange

1.2.4 Allocation of clamps for system 4

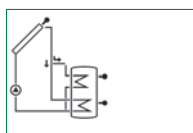

Arr 4

Solar system and store charge in layers with 1 store, 3 sensors, 1 solar pump and 3-way-valve for store charge in layers. The sensor S4 / TRF can optionally be used for heat quantity balancing.

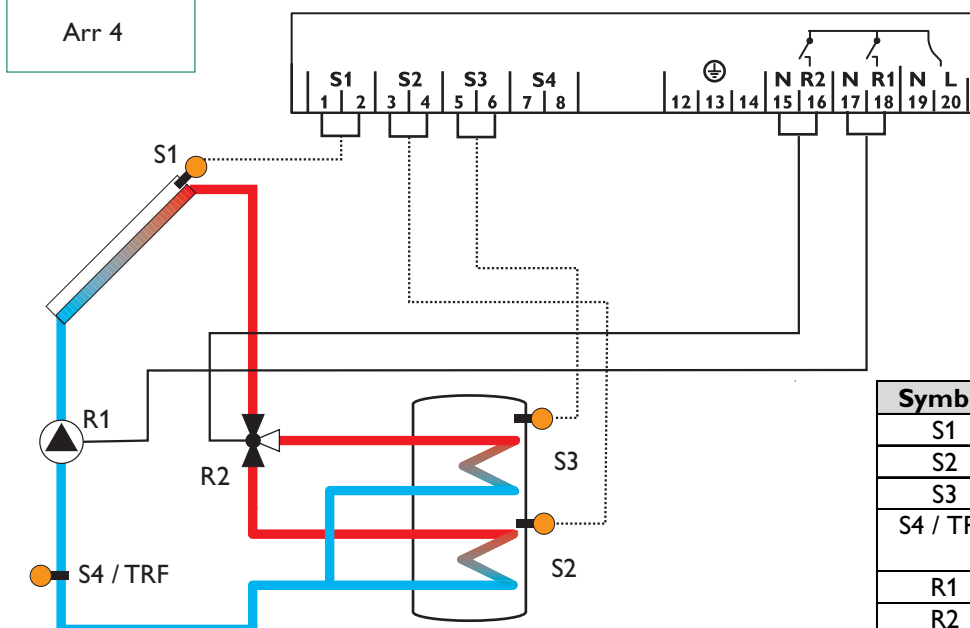

Symbol	Specification
S1	collector sensor
S2	store sensor lower
S3	store sensor at the top
S4 / TRF	sensor for heat quantity blancing (optionally)
R1	solar pump
R2	3-way-valve

1.2.5 Allocation of clamps for system 5

2-store-solar system with valve logic with 2 stores, 3 sensors, 1 solar pump and 1 3-way-valve. The sensor S4 / TRF can optionally be used for heat quantity balancing.

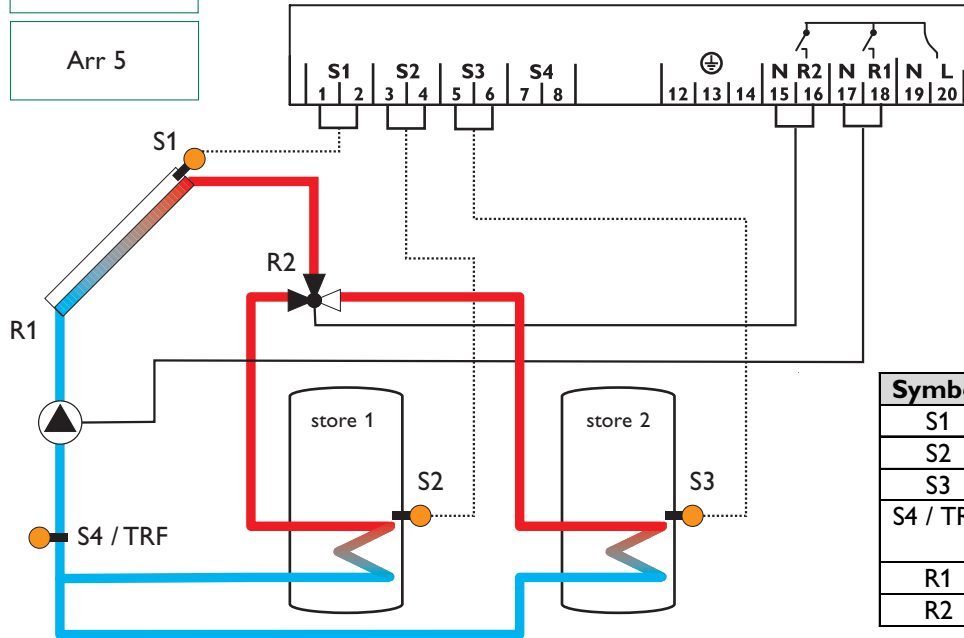
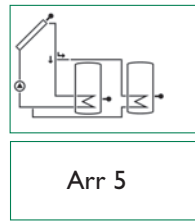

Symbol	Specification
S1	collector sensor
S2	store sensor 1
S3	store sensor 2
S4 / TRF	sensor for heat quantity balancing (optionally)
R1	solar pump
R2	3-way-valve

1.2.6 Allocation of clamps for system 6

2-store-solar system with pump logic with 2 stores, 3 sensors and 2 solar pumps.

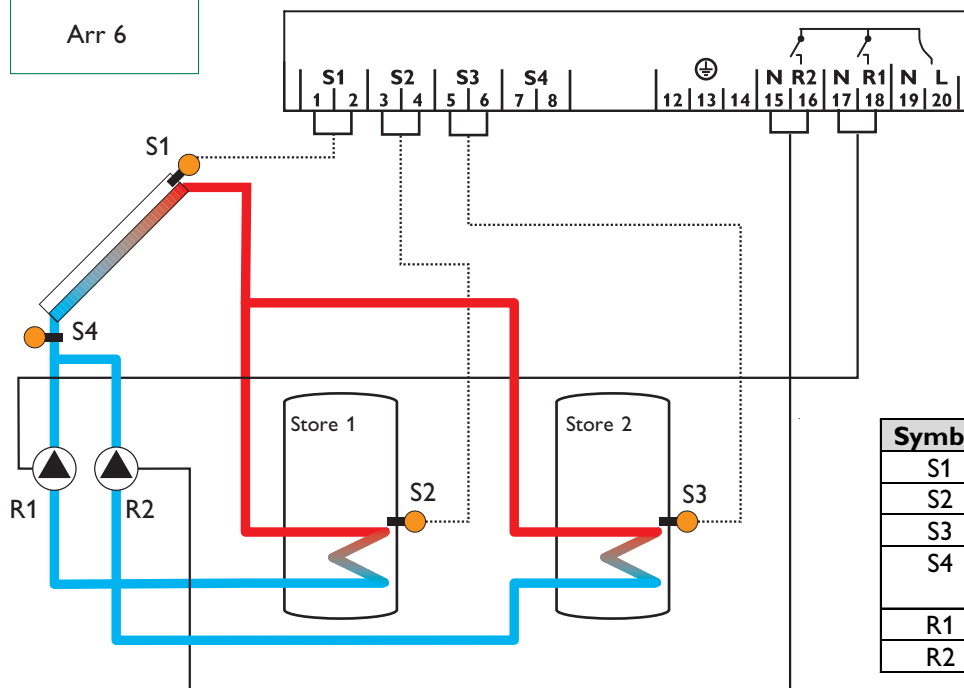
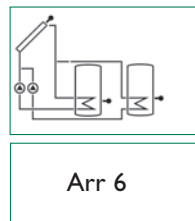

Symbol	Specification
S1	collector sensor
S2	store sensor 1
S3	store sensor 2
S4	measuring sensor (optionally)
R1	solar pump
R2	solar pump

1.2.7 Allocation of clamps for system 7

Solar system with east-west collectors, 1 store, 3 sensors and 2 solar pumps.

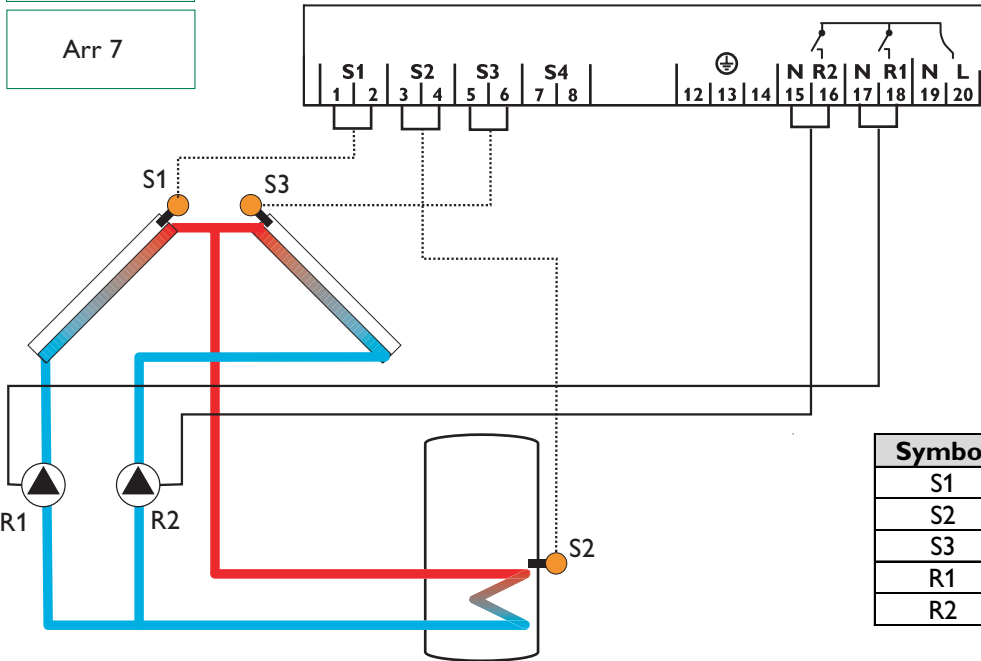
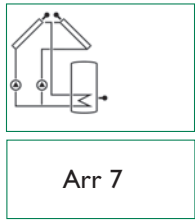

Symbol	Specification
S1	collector sensor 1
S2	store sensor
S3	collector sensor 2
R1	solar pump collector 1
R2	solar pump collector 2

1.2.8 Allocation of clamps for system 8

Solar system with after-heating by solid fuel boiler with 1 store, 4 sensors, 1 solar pump and 1 pump for after-heating.

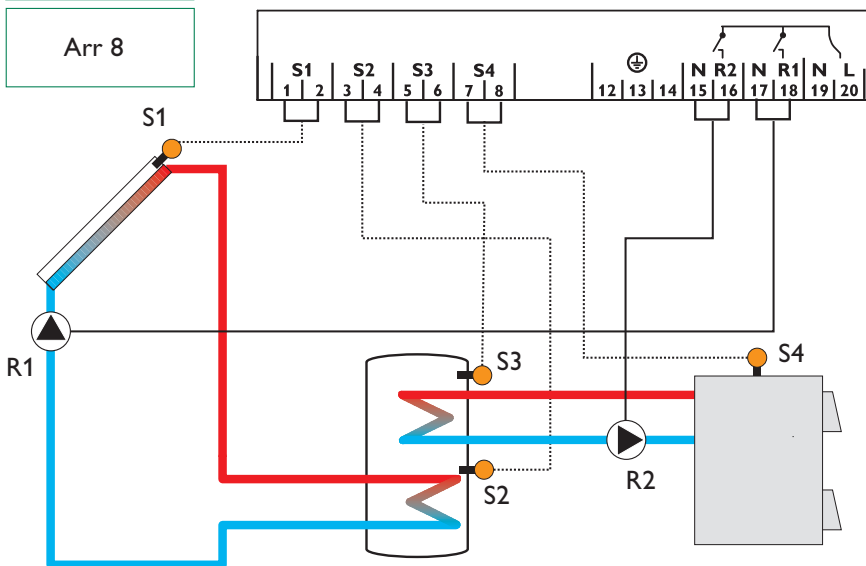
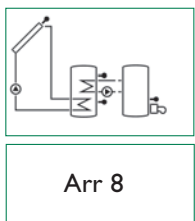

Symbol	Specification
S1	collector sensor
S2	store sensor lower
S3	store sensor at the top
S4	sensor for solid hot fuel boiler
R1	solar pump
R2	pump for solid hot fuel boiler

1.2.9 Allocation of clamps for system 9

Solar system and heating circuit reverse raising with 1 store, 4 sensors, 1 solar pump and 1 3-way-valve for heating circuit reverse raising.

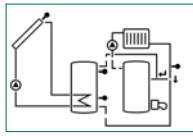

Arr 9

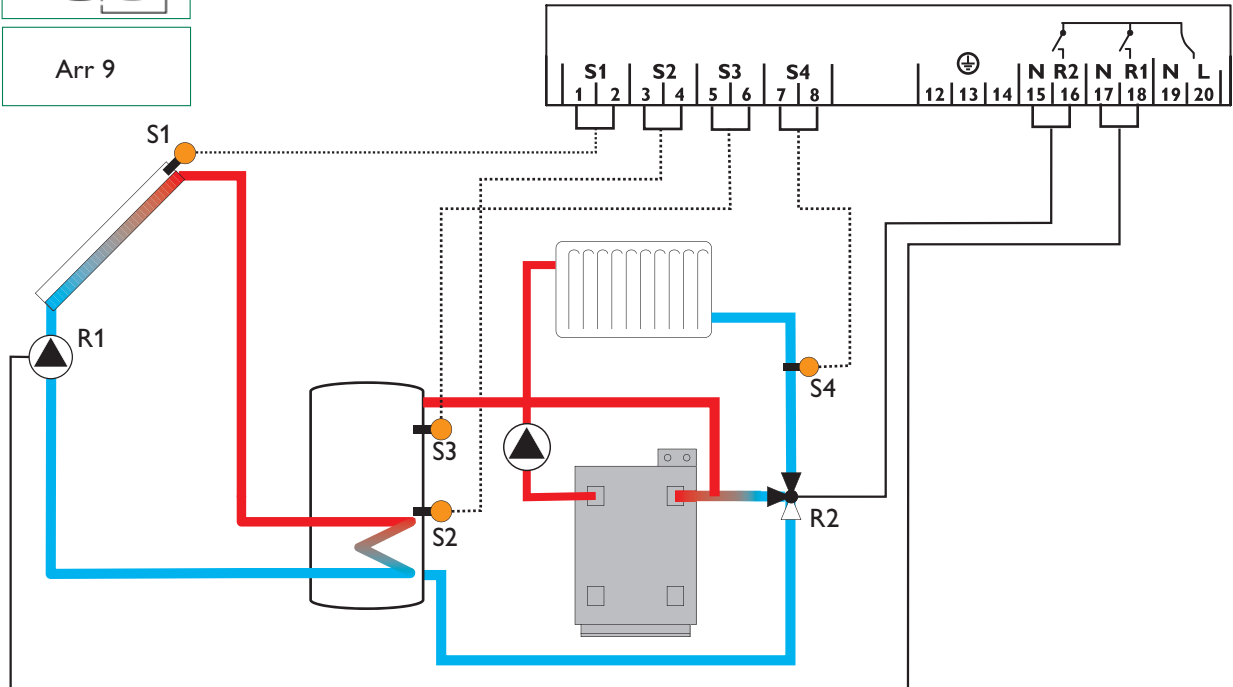

Symbol	Specification
S1	collector sensor
S2	store sensor lower
S3	store sensor at the top
S4	heating circuit return
R1	solar pump
R2	3-way-valve

2. Operation and function

2.1 Pushbuttons for adjustment

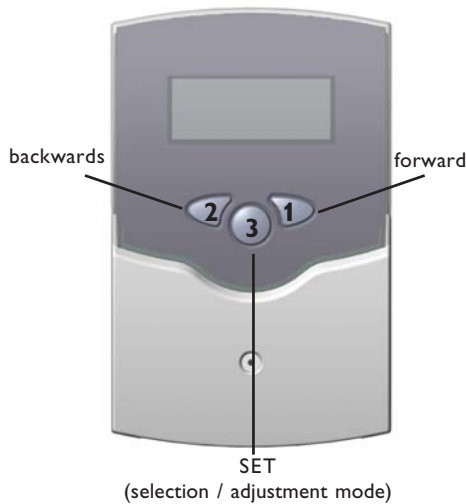

The controller is operated by 3 pushbuttons below the display. The forward-key (1) is used for scrolling forward through the indication menu or to increase the adjustment values. The backwards-key (2) is accordingly used for the reverse function.

For adjustment of last indication channel, keep button 1 pressed for 3 seconds. If an **adjustment value** is shown on the display, **SEt** is indicated. In this case you can press the key „Set“ (3) in order to change into input mode.

Select a channel by keys 1 and 2
 Shortly press key 3, so that „SEt“ flashes
 Adjust the value by keys 1 and 2
 Shortly press key 3, so that „SEt“ permanently appears, the adjusted value is now saved.

2.2 System monitoring display

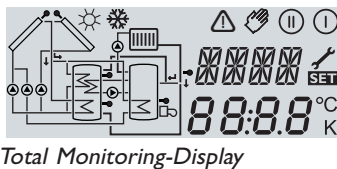

Total Monitoring-Display

The system monitoring display consists of 3 blocks: **indication of the channel, tool bar and system screen** (active system scheme).

2.2.1 Channel indication

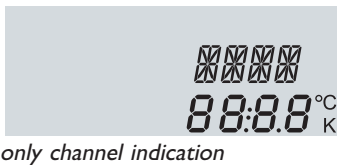

only channel indication

The **indication channel** consists of two lines. The upper line is an alphanumeric 16-segment indication, in which mainly the channel names / menu items are shown. In the lower 7-segment indication, the channel values and the adjustment parameter are indicated. Temperatures and temperature differences are indicated in °C or K.

2.2.2 Tool bar



only tool bar

The additional symbols of the **tool bar** indicate the current system status.

symbol	standard	flashing
	relay 1 activ	
	relay 2 activ	
	maximum store limitation active / maximum store temperature exceeded	collector cooling function active reccoling function active
	option antifreeze function active	collector minimum limitation active antifreeze function active
		collector security shutdown active or store security shutdown active
		sensor defect
		manual operation active
		an adjustment channel is changed SET-mode

2.2.3 System screen

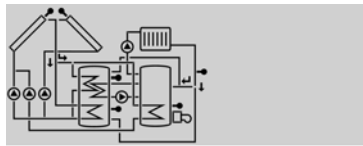

only system screen

The system screen (active system scheme) shows the schemes selected on the controller. It consists of several system component symbols, which are - depending on the current status of the system - either flashing, permanently shown or hidden.

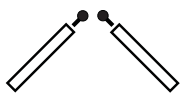
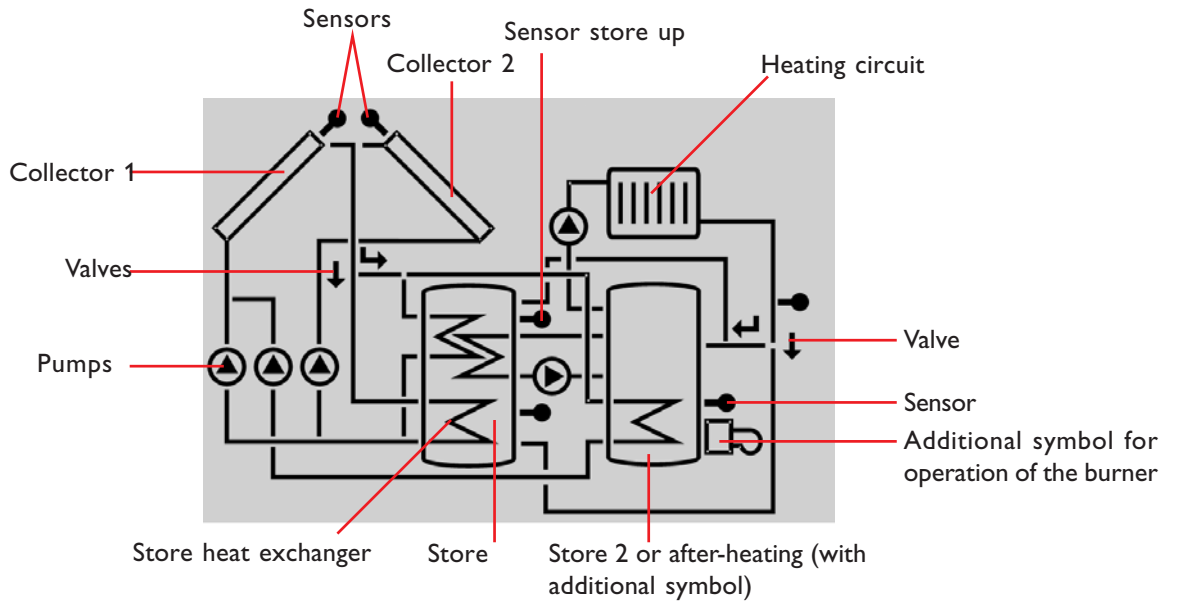

Collectors
with collector sensor

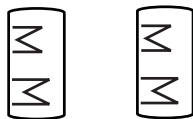

Store 1 and 2
with heat exchanger



3-way-valves
The flow direction or the current breaking capacity are always shown.



Temperature sensor



Heating circuit



Pump

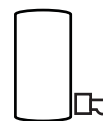

After-heating
with burner symbol

2.3 Blinking codes

2.3.1 System screen blinking codes

- Pumps are blinking during starting phase
- Sensors are blinking if the respective sensor-indication channel is selected.
- Sensors are quickly blinking in case of sensor defect.
- Burner symbol is blinking if after-heating is activated.

2.3.2 LED blinking codes

- Constantly green: everything all right
- Red/green blinking: initialisation phase
manual operation
- Red blinking: sensor defect
(sensor symbol is quickly blinking)

3. Commissioning

On commissioning you have to adjust primarily the system scheme

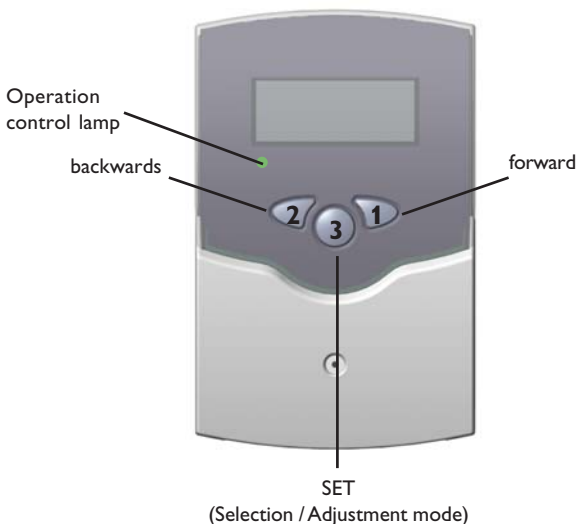

1. Ac power supply must be activated. The controller passes an initialisation phase in which the operating control lamp flashes red and green. After having finished the initialisation, the controller is in automatic operation with factory settings. The preadjusted system scheme is Arr 1.

2. - select Arr

- change into **SET**-mode (see 2.1)
- select the system scheme by Arr-characteristics
- adjustment is saved by pressing button **SET**

Now the controller is ready for operation and should enable an optimum operation of the solar system by the factory settings made.

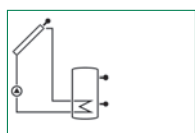

Arr 1

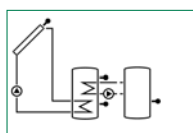

Arr 2

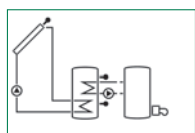

Arr 3

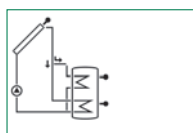

Arr 4

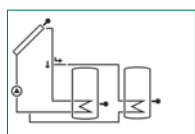

Arr 5

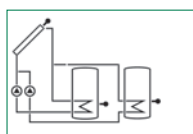

Arr 6

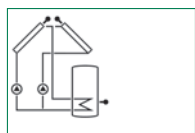

Arr 7

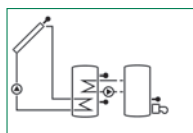

Arr 8

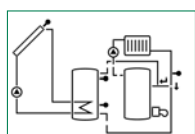

Arr 9

System survey:

Arr 1 : standard solar system

Arr 2 : solar system with heat exchange

Arr 3 : solar system with after-heating

Arr 4 : solar system with store charge in layers

Arr 5 : 2-store solar system with valve logic

Arr 6 : 2-store solar system with pump logic

Arr 7 : solar system with 2 collectors and 1 store

Arr 8 : solar system with after-heating by solid hot fuel boilers

Arr 9 : solar system with heating circuit reverse raising

4. Controller parameter and indication channels

4.1 Channel-overview

Legend:

x

Corresponding channel is available.

x*

Corresponding channel is available if the appropriate option is activated.

Please note:

S3 and S4 are only indicated in case of sensors connected.

①

Corresponding channel is only available if the option heat quantity measurement is **activated** (OHQM).

②

Corresponding channel is only available if the option heat quantity measurement is **deactivated** (OHQM).

MEDT

The channel antifreeze content (MED%) is only shown if there is not used **water or Tyfocor LS / G-LS (MEDT 0 or 3) as antifreeze**. The adjustment of the content of antifreeze does only make sense when using antifreeze components in the solar circuit.

channel	Arr									Specification	page
	1	2	3	4	5	6	7	8	9		
COL	x	x	x	x	x	x		x	x	Temperature collector 1	15
COL1							x			Temperature collector 1	15
TST	x						x			Temperature store 1	15
TSTL			x	x				x	x	Temperature store 1	15
TST1		x			x	x				Temperature store 1 below	15
TSTU		x	x	x				x	x	Temperature store 1 below	15
TST2		x			x	x				Temperature store 2 below	15
TFSB								x		Temperature solid hot fuel boiler	15
TRET									x	Temperature heating circuit	15
COL2							x			Temperature collector 2	15
S3	x									Temperature sensor 3	15
TRF	①		①	①	①					Temperature return sensor	15
S4	②		②	②	②	x	x			Temperature sensor 4	15
n %	x			x	x				x	Pump speed relay 1	15
n1 %		x	x			x	x	x		Pump speed relay 1	15
n2 %		x				x	x	x		Pump speed relay 2	15
h P	x			x	x				x	Operating hours relay 1	16
h P1		x	x			x	x	x		Operating hours relay 1	16
h P2		x	x			x	x	x		Operating hours relay 2	16
kWh	①		①	①	①					Heat quantity kWh	16
MWh	①		①	①	①					Heat quantity MWh	16
Arr	1-9									System	12
DT O	x	x	x				x	x	x	Switch-on temperature difference	17
DT1O				x	x	x				Switch-on temperature difference 1	17
DT F	x	x	x				x	x	x	Switch-off temperature difference 1	17
DT S	x	x	x				x	x	x	Nominal temperature difference	17
RIS	x	x	x				x	x	x	Increase	17
DT1F				x	x	x				Switch-off temperature difference	17
DT1S				x	x	x				Nominal temperature difference 1	17
RIS1				x	x	x				Increase 1	17
S MX	x	x	x				x	x	x	Maximum temperature store 1	17
S1MX				x	x	x				Maximum temperature store 1	17
DT2O				x	x	x				Switch-on temperature difference 2	17
DT2F				x	x	x				Switch-off temperature difference 2	17
DT2S				x	x	x				nominal temperature difference 2	17
RIS2				x	x	x				Increase 2	17
S2MX				x	x	x				Maximum temperature store 2	17
EM	x	x	x	x	x	x		x	x	emergency temperature collector 1	17
EM1							x			emergency temperature collector 1	17

channel	ANL									Specification	page
	1	2	3	4	5	6	7	8	9		
OCX	x	x	x	x	x	x		x	x	option collector cooling collector 1	17
OCX1							x			option collector cooling collector 1	17
CMX	x*	x*	x*	x*	x*	x*		x*	x*	maximum temperature collector 1	18
CMX1							x*			maximum temperature collector 1	18
OCN	x	x	x	x	x	x		x	x	option minimum limitation collector 1	18
OCN1							x			option minimum limitation collector 1	18
CMN	x*	x*	x*	x*	x*	x*		x*	x*	minimun temperature collector 1	18
CMN1							x*			minimun temperature collector 1	18
OCF	x	x	x	x	x	x		x	x	option antifreeze collector 1	18
OCF1							x			option antifreeze collector 1	18
CFR	x*	x*	x*	x*	x*	x*		x*	x*	antifreeze temperature collector 1	18
CFR1							x*			antifreeze temperature collector 1	18
EM2							x			emergency temperature collector 2	17
OCX2							x			option collector cooling collector 2	17
CMX2							x*			maximum temperature collector 2	18
OCN2							x			option mimum limitation collector 2	18
CMN2							x*			minium temperature collector 2	18
OCF2							x			option antifreeze collector 2	18
CFR2							x*			antifreeze temperature collector 2	18
PRIO				x	x	x				priority	18
tSP				x	x	x				stop time	18
tRUN				x	x	x				Cirulation time	18
OREC	x	x	x	x	x	x	x	x	x	option reccoling	19
O TC	x	x	x	x	x	x	x	x	x	option tube collector	19
DT3O		x						x	x	switch-on temperature difference 3	17
DT3F		x						x	x	switch-off temperature difference 3	17
DT3S		x						x		nominal temperature $\Delta T3$	17
RIS3		x						x		Increase $\Delta T3$	17
MX3O		x						x		switch-on treshold for maximum temperature	17
MX3F		x						x		switch-off treshold for maximum temp.	17
MN3O		x						x		switch-on treshold for minimum temperature	17
MN3F		x						x		switch-off treshold for minimum temp.	17
AH O			x							switch-on temp. for thermostat 1	20
AH F			x							switch-off temp. for thermostat 1	20
OHQM	x		x	x	x					option WMZ	16
FMAX	①		①	①	①					maximum flow	16
MEDT	①		①	①	①					antifreeze type	16
MED%	MEDT		MEDT	MEDT	MEDT					antifreeze content	16
nMN	x			x	x				x	minimum pump speed relay 1	20
n1MN		x	x			x	x	x		minimum pump speed relay 1	20
n2MN		x				x	x	x		minimum pump speed relay 2	20
HND1	x	x	x	x	x	x	x	x	x	manual operation relay 1	20
HND2	x	x	x	x	x	x	x	x	x	manual operation relay 2	20
LANG	x	x	x	x	x	x	x	x	x	language	20
PROG					XX.XX					program number	20
VERS					X.XX					version number	20

4.1.1 Indication of collector temperatures

COL, COL1, COL2:

Collector temperature
display range: -40 ... +250 °C



Shows the current collector temperature.

- COL : collector temperature (1-collector-system)
- COL1: collector temperature 1
- COL2: collector temperature 2

4.1.2 Indication of store temperatures

TST,TSTL,TSTU, TST1,TST2:

Store temperatures
Display range: -40 ... +250 °C



Shows the current store temperature.

- TST : store temperature (1-store-system)
- TSTL : store temperature lower
- TSTU : store temperature above
- TST1 : temperature store 1
- TST2 : temperature store 2

4.1.3 Indication of sensor 3 and sensor 4

S3, S4:

Sensor temperatures
Display range: -40 ... +250 °C

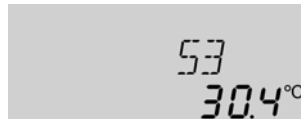

Shows the current temperature of the corresponding additional sensor (without control function).

- S3 : temperature sensor 3
- S4 : temperature sensor 4

Please note:

S3 and S4 are only indicated if the temperature sensors are connected (shown).

4.1.4 Indication of other temperatures

TFSB,TRET,TRF:

other measuring temperatures
Display range: -40 ... +250 °C

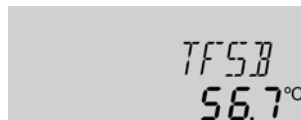

Shows the current temperature of the corresponding sensor.

- TFSB : temperature solid hot fuel boiler
- TRET : temperature heating reverse raising
- TRF : temperature return flow

4.1.5 Indication of current pump speed

n %, n1 %, n2 %:

current pump speed
Display range: 30 ... 100 %



Shows the current pump speed of the corresponding pump.

- n % : current pump speed (1-pump-system)
- n1 % : current pump speed pump 1
- n2 % : current pump speed pump 2

4.1.6 Operating hours counter

h P / h P1 / h P2:
Operating hours counter
Display channel

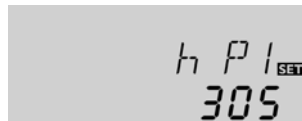

The operating hours counter adds up the solar operating hours of the respective relay (**h P / h P1 / h P2**). Full hours are shown on the display.

The operating hours added up can be reset. As soon as one operating hours channel is selected, the symbol **SET** is permanently shown on the display. The button SET (3) must be pressed for approx. 2 seconds in order to get back into the RESET-mode of the counter. The display-symbol **SET** is flashing and the operating hours will be set to 0. In order to finish the RESET-procedure, the button **SET** must be pressed in order to confirm.

In order to interrupt the RESET-procedure, no button should be pressed for about 5 seconds. The controller returns automatically into the indication mode.

4.1.7 Heat quantity balancing

OHQM: Heat quantity balancing
Adjustment range: OFF ... ON
Factory setting: OFF



A heat quantity balancing is possible for the basic systems (Arr) 1, 3, 4 and 5 in conjunction with a flowmeter. You just have to activate the option heat quantity balancing in the channel **OHQM**

FMAX: Volume flow in l/min
Adjustment range 0 ... 20
in steps of 0,1
Factory setting 6,0



The volume flow readable at the flowmeter (l/min) must be adjusted in the channel **FMAX**. Antifreeze type and concentration of the heat transfer medium are indicated on the channels **MEDT** and **MED%**.

MEDT: Type of antifreeze
Adjustment range 0 ... 3
Factory setting 1



Type of antifreeze:

- 0 : water
- 1 : propylene glycol
- 2 : ethylene glycol
- 3 : Tyfocor® LS / G-LS

MED%: Concentration of antifreeze in (Vol-) %
MED% is blinded out by MEDT 0 and 3.
Adjustment range 20 ... 70
Factory setting 45



kWh/MWh: Heat quantity in kWh / MWh
Display channel



The heat quantity transported is measured by the indication of the volume flow and the reference sensor of feed flow S1 and return flow S4. It is shown in kWh-parts in the indication channel **kWh** and in MWh-parts in the indication channel **MWh**. The sum of both channels form the total heat output.

The heat quantity added up can be reset. As soon as one of the display channels of the heat quantity is selected, the symbol **SET** is permanently shown on the display. The button SET (3) must be pressed for approx. 2 seconds in order to get back into the RESET-mode of the counter. The display-symbol **SET** is flashing and the value for heat quantity will be set to 0. In order to finish the RESET-procedure, the button **SET** must be pressed in order to confirm.

In order to interrupt the RESET-procedure, no button should be pressed for about 5 seconds. The controller returns automatically into the indication mode.

4.1.8 ΔT-regulation

DT O / DT10 / DT20 / DT30:

Switch-on temperature
Adjustment range 1,0...20,0 K
Factory setting 6.0



DT F / DT1F / DT2F / DT3F:

Switch-off temperature diff.
Adjustment range
0,5 ... 19,5 K

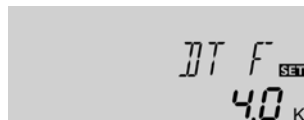

Please note: Switch-on temperature difference DO must be at least 1 K higher than the switch-off temperature-difference DF.

DT S / DT1S / DT2S / DT3S:

Nominal temperature difference
Adjustment range 1,5...30,0 K
Factory setting 10.0



RIS / RIS1 / RIS2 / RIS3:

Raise
Adjustment range 1 ... 20 K
Factory setting 2 K

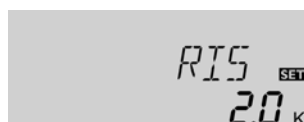

4.1.9 Maximum store temperature

S MX / S1MX / S2MX:

Maximum store temp.
Adjustment range 2..95 °C
Factory setting 60 °C

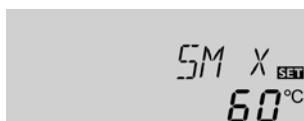

4.1.10 ΔT-regulation (solid fuel boilers and heat exchange)

Maximum temperature limitation

MX30 / MX3F:

Maximum temperature limitation
Adjustment range
0,0 ... 95,0 °C
Factory setting
MX30 60,0 °C
MX3F 58,0 °C

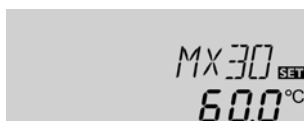

Minimum temperature limitation

MN30 / MN3F:

Minimum temperature limitation
Adjustment range
0,0 ... 90,0 °C
Factory setting:
Arr = 2
MN30 5,0 °C
MN3F 10,0 °C
Arr = 8
MN30 60,0 °C
MN3F 65,0 °C



Primarily the controller works in the same way as a standard differential controller. If the switch-on difference (**DT O / DT10 / DT20**) is reached, the pump is activated and after having got an impulse (10 s) a minimum pump speed (nMN = 30 %) is run. If the adjusted nominal value of the temperature difference (**DT S / DT1S / DT2S / DT3S**) is reached, the pump speed is increased by one step (10%). If the difference increases by 2 K (**RIS / RIS1 / RIS2 / RIS3**), the pump speed is increased by 10 % respectively until the maximum pump speed of 100 % is reached. The response of the controller can be adapted by means of the parameter „Anstieg“ (raise). If the adjusted switch-off temperature is underrun (**DT F / DT1F / DT2F**), the controller switches-off.

If the adjusted maximum temperature is exceeded, a further loading of the store is stopped so that a damaging overheating can be avoided. If the maximum store temperature is exceeded, in the display is shown and ☀.

Please note: The controller is equipped with a security-switch-off of the store, which avoids a further loading of the store if 95 °C is reached at the store.

The controller is equipped with an independent temperature differential regulation for which minimum and maximum temperature limitations as well as corresponding switch-on and -off temperatures can be separately adjusted. Only possible for Arr = 2 and 8 (e.g. for solid hot fuel boilers or heat exchange regulation).

Is the adjusted value **MX30** exceeded, the relays 2 will be deactivated. By falling below **MX3F**, the relays will be switched on again.

Reference sensor:
S3 by Arr 8 (TSTU)
S4 by Arr 2 (TST2)

Is the adjusted value **MN30** underrun, the relays 2 will be deactivated. By falling below **MN3F**, the relays will be switched on again.

Reference sensor:
S4 by Arr 8 (TFSB)
S3 by Arr 2 (TSTU)

Parallely obtain both switch on- and switch off temperature differences **DT30** and **DT3F** for the maximal- and minimal temperature limit.

4.1.11 Limit collector temperature Collector emergency shutdown

EM / EM1 / EM2:

Limit collector temperature
Adjustment range
110 ... 200 °C,
Factory setting 140 °C



If the adjusted collector limit temperature (**EM / EM1 / EM2**) is exceeded the solar pump (R1/R2) is deactivated in order to avoid a damaging overheating of the solar components (collector emergency shutdown). The limit temperature is set to 140 °C by RESOL but it can be changed within the adjustment range of 110 ... 200 °C. In the display is shown Δ (flashing).

4.1.12 System cooling

OCX / OCX1 / OCX2:

Option system cooling
Adjustment OFF ... ON
Factory setting OFF



CMX / CMX1 / CMX2:

Maximum collector temp.
Adjustment range
100 ... 190 °C
Factory setting 120 °C



If the adjusted maximum store temperature is reached, the solar system switches-off. If now the collector temperature raises to the adjusted maximum collector temperature (**CMX / CMX1 / CMX2**), the solar pump remains activated until this limit temperature value is again underrun. The store temperature might continue to raise (subordinated active maximum store temperature), but only until 95 °C (emergency shutdown of the store). If the store temperature is higher than the maximum store temperature (**SMX / S1MX / S2MX**) and the collector temperature is by at least 5K lower than the store temperature, the solar system remains activated until the store is again cooled down by the collector and the tubes under the adjusted maximum temperature (**SMX / S1MX / S2MX**) (only by activated **OREC** function).

In case of active system cooling on the display is shown \star (flashing). Due to the cooling function the solar system can be kept operable for a longer period on hot summer days and a thermal release of the collector and the heat transfer medium is ensured as well.

4.1.13 Option minimum collector limitation

OCN / OCN1 / OCN2:

Minimum collector limitation
Adjustment range OFF / ON
Factory setting OFF



CMN / CMN1 / CMN2:

Minimum collector temperature
Adjustment range
-10 ... 90 °C
Factory setting 10 °C



The minimum collector temperature is a minimum switching temperature, which must be exceeded so that the solar pump (R1/R2) is switched-on. The minimum temperature shall avoid a steady starting-up of the solar pump (or solid fuel boiler charging pumps) for low collector temperatures. If the minimum temperature is underrun, in the display is shown \star (flashing).

4.1.14 Option antifreeze function

OCF / OCF1 / OCF2:

Antifreeze function
Adjustment range
OFF / ON
Factory setting OFF



CFR / CFR1 / CFR2:

Antifreeze temperature
Adjustment range
-10 ... 10 °C
Factory setting 4,0 °C



The antifreeze function activates the loading circuit between collector and store if the adjusted antifreeze function is underrun in order to protect the medium that it will not freeze or „get thick“. If the adjusted frost protection temperature is exceeded by 1 °C, the loading circuit will be deactivated.

Please note:

As there is only a limited heat quantity of the store available for this function, the anti freeze function should only be used in regions with few days of temperatures around freezing point.

4.1.15 Oscillating charge

Respective adjustment values:

priority [PRIO]

oscillating break-time [tSP]

oscillating charge-time [tRUN]

Factory setting

1 (2 / Arr 4, 5)

2 min.

15 min.

Adjustment range

0-2

1-30 min.

1-30 min.

The priority logic of the controller

DeltaSol® BS Pro:

Priority:



The above-mentioned options and parameter only have a meaning in multi-store systems (system Arr = 4, 5, 6). If **priority 0** is adjusted, the stores which show a temperature difference to the collector are loaded in numerical order (store 1 or store 2). In general, at that time, only one store is loaded. For Arr= 5, 6 parallel loading is also possible.

Oscillating break time / oscillating charge time / collector rising temperature:

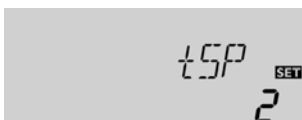

The controller checks the stores regarding loading facilities (switch-on difference). If the priority store cannot be loaded, the lower-ranking store is checked. If the lower-ranking store can be charged, this is effected by the so-called „oscilating charge time“ (**tRUN**). After termination of the oscilating charge time, loading is stopped. The controller controls the increase in collector temperature. If it increases by the collector rising temperature (ΔT_{Col} 2 K, fixed software value), the expired break time is again reset to zero and the oscilating break time starts again. If the switch-on conditions of the priority store is not reached, the loading of the lower-ranking store is continued. If the priority switch has reached its maximum temperature, the oscilating charge is not effected.

4.1.16 Recooling function

OREC:

option recooling

adjustment range

OFF ... ON

Factory setting: OFF

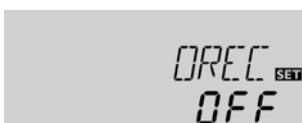

If the adjusted maximum store temperaute (**S MX, S1MX**) is reached, the solar pump remains activated in order to avoid an overheating of the collector. The temperature of the first store might continue to increase but only up to 95 °C (emergency shutdown of the store).

In the evening the solar system continues running until the store is cooled down to the adjusted maximum store temperature via collector and pipes.

4.1.17 Tube collector special function

OTC:

Tube collector special function

Adjustment range:

OFF ... ON

Factory setting: OFF

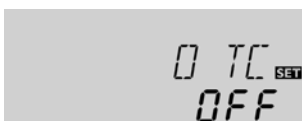

If the controller measures an increase of 2 K compared to the collector temperature stored at last, the solar pump is switched-on to 100 % for about 30 seconds. After expiration of the solar pump runtime the current collector temperature is stored as new reference value. If the measured temperature (new reference value) is again exceeded by 2 K, the solar pump again switches-on for 30 seconds. If the switch-on difference between collector and store is again exceeded during runtime of the solar pump or the standstil of the system, the controller automatically switches over to solar charging.

If the collector temperature drops by 2 K during standstill, the switch-on value for the special tube collector function will be recalculated.

4.1.18 Thermostat function
(Arr = 3)

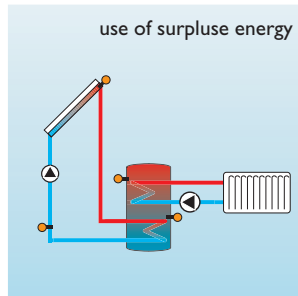
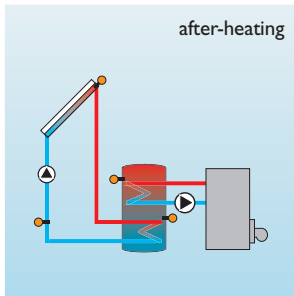

The thermostat function works independently from the solar operation and can e.g. be used for use of surplus energy or an after-heating.

- **AH O < AH F**
the thermostat function is used for after-heating
- **NH O > AH F**
the thermostat function is used for use of surplus energy

On the display is shown  if the second relay output is activated.

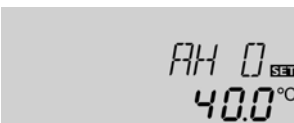

AH O:
Thermostat-switch-on temperature
Adjustment range:
0,0 ... 95,0 °C
Factory setting: 40,0 °C

AH F:
Thermostat-switch-off temperature
Adjustment range:
0,0 ... 95,0 °C
Factory setting: 45,0 °C

4.1.19 Pump speed control

nMN, n1MN, n2MN:
Pump speed control
Adjustment range:
30 ... 100
Factory setting: 30



A relative minimum pump speed is specified for pumps connected at the outputs R1 and R2 via adjustment channels **nMN**, **n1MN** and **n2MN**.

Attention:



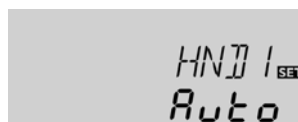
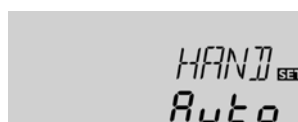

When using consumers (e.g. valves) which are not pump speed controlled, the value must be adjusted to 100 % in order to deactivate the pump speed control.

4.1.20 Operating mode

HAND/HND1/HND2:
Operating mode
Adjustment range:
OFF, AUTO, ON
Factory setting: AUTO



For control- and service work the operating mode of the controller can be manually adjusted by selecting the adjustment value HND1 / HND2, in which the following adjustments can be made:

- **HND1 / HND2**
Operating mode
OFF : relay off  (flashing) + 
- AUTO : relay in automatic operation
- ON : relay on  (flashing) + 

4.1.21 Language

LANG:
Adjustment of language
Adjustment range: dE, En
Factory setting: dE



The menu language can be adjusted in this channel.

- dE : German
- En : English

5. Tips for fault localization

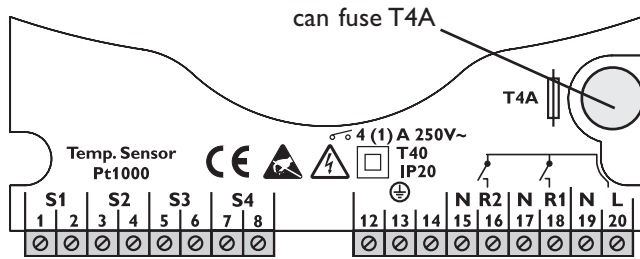

If a malfunction occurs, a notification is given on the display of the controller:

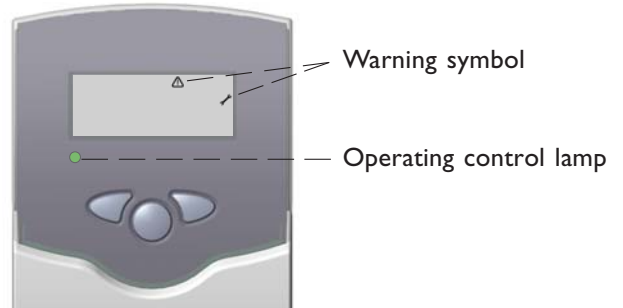

Operating control lamp flashes red. On the display appears the symbol and the symbol .

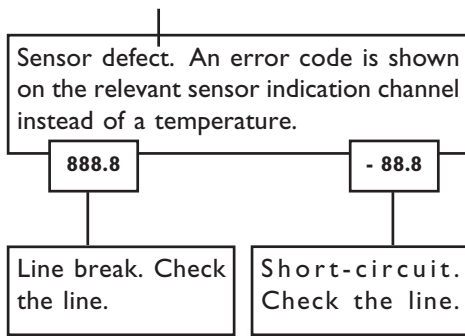

Pt1000-temperature sensors pinched off can be checked with an ohmmeter. In the following the resistance values corresponding to different temperatures are listed.

°C	Ω	°C	Ω
-10	961	55	1213
-5	980	60	1232
0	1000	65	1252
5	1019	70	1271
10	1039	75	1290
15	1058	80	1309
20	1078	85	1328
25	1097	90	1347
30	1117	95	1366
35	1136	100	1385
40	1155	105	1404
45	1175	110	1423
50	1194	115	1442

Resistance values of the Pt1000-sensors

Operating control lamp goes permanently out.

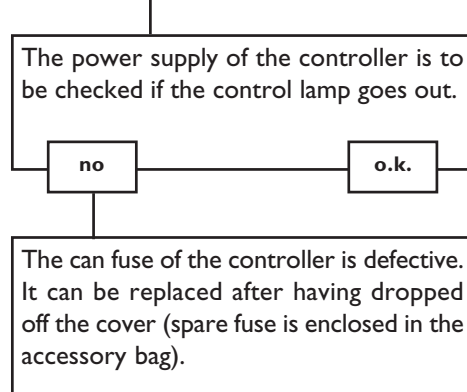

5.1 Various:

Pump is overheated, but no heat transfer from collector to the store, feed flow and return flow are equally warm, perhaps also bubble in the lines.

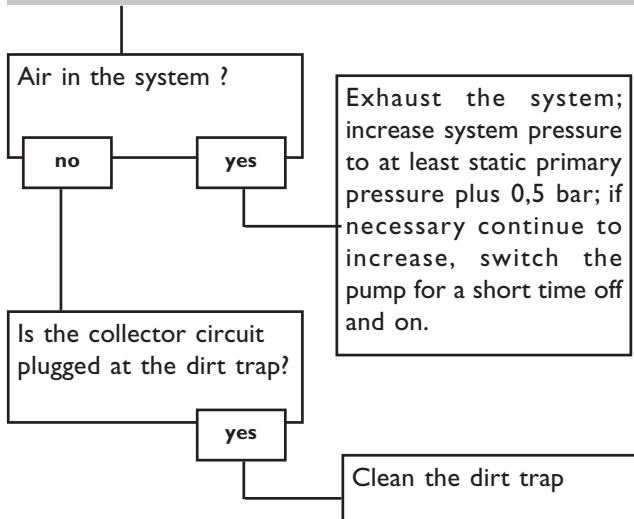

Pump starts for a short moment, switches-off, switches-on again, etc. („controller hunting“)

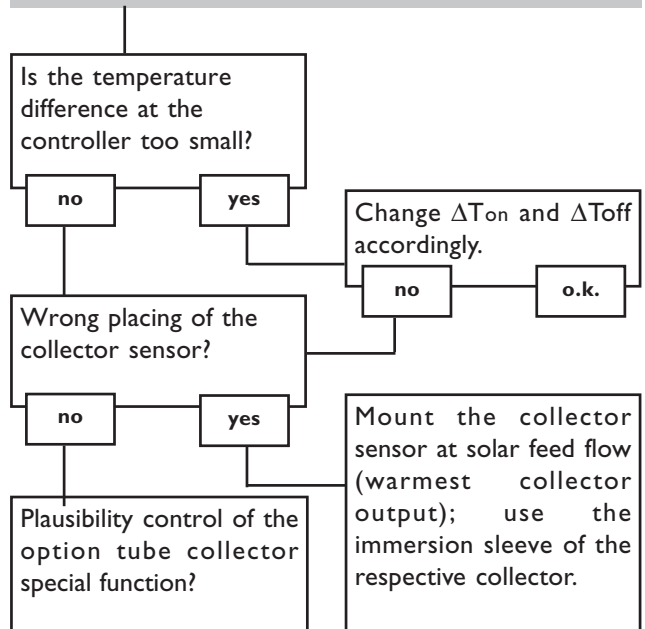

Pump starts up very late and stops working soon.

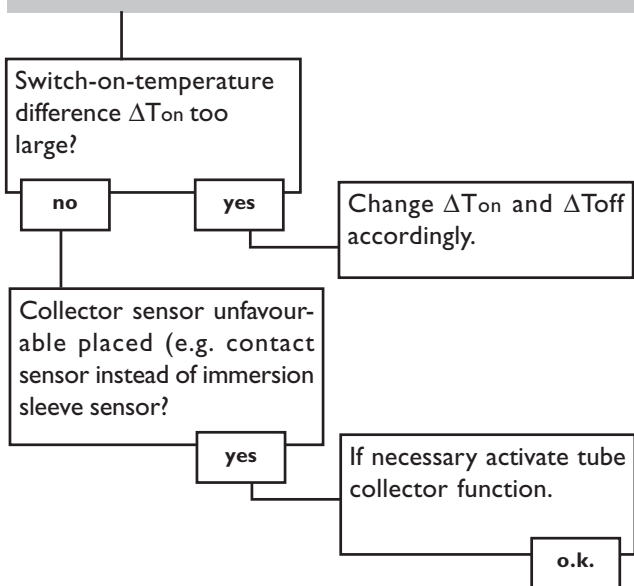

The temperature difference between store and collector increases enormously during operation; the collector circuit cannot dissipate the heat.

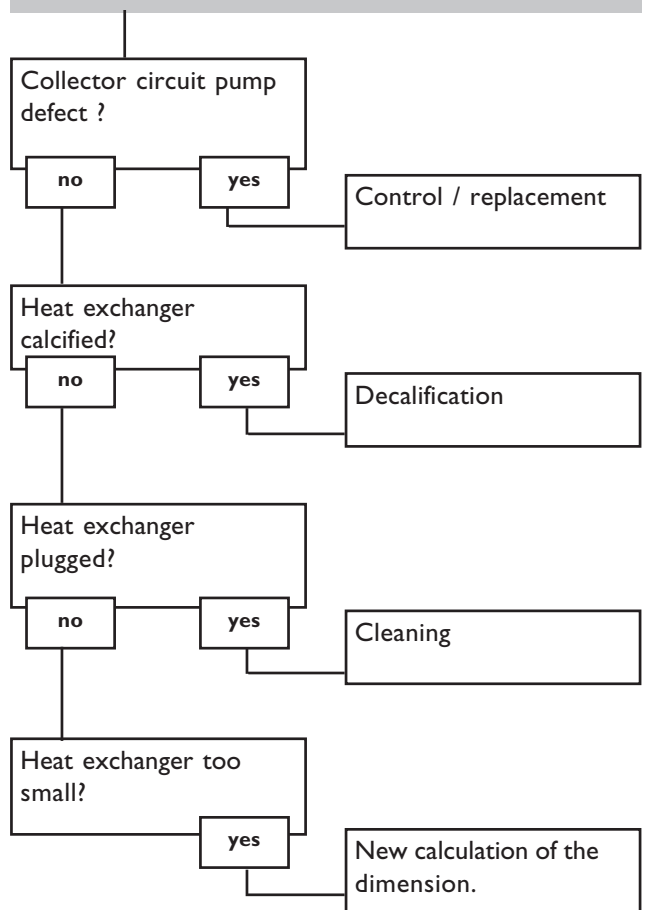

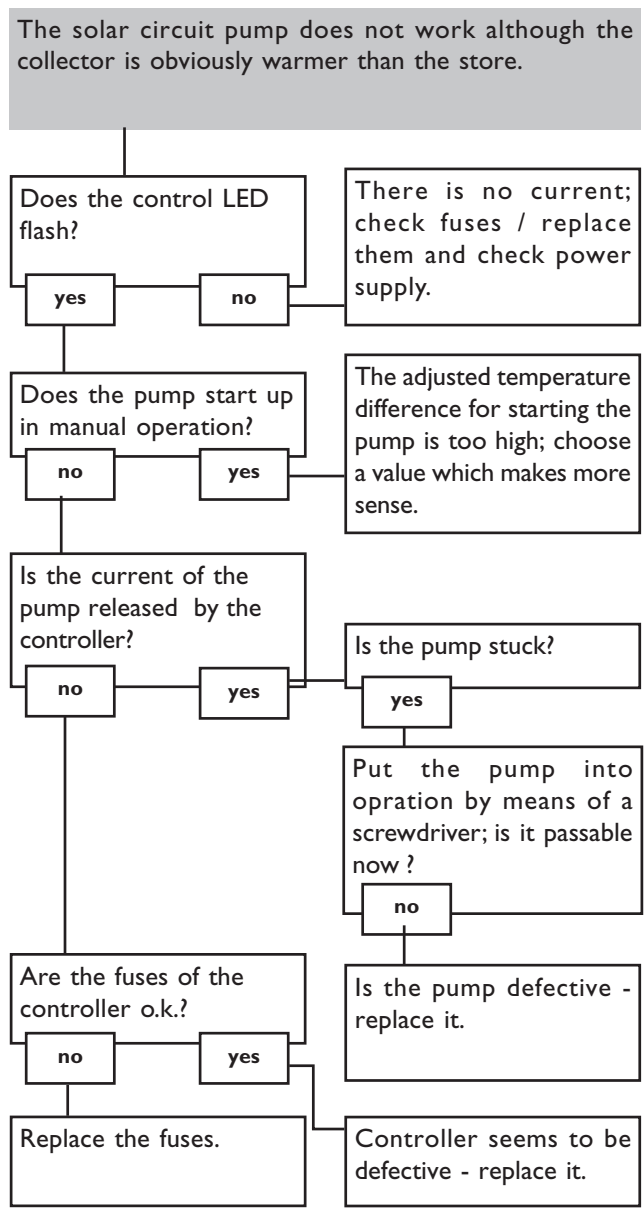
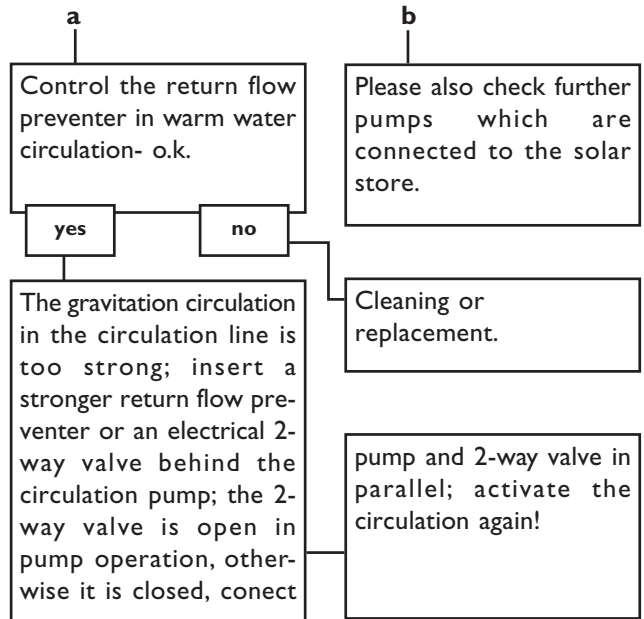
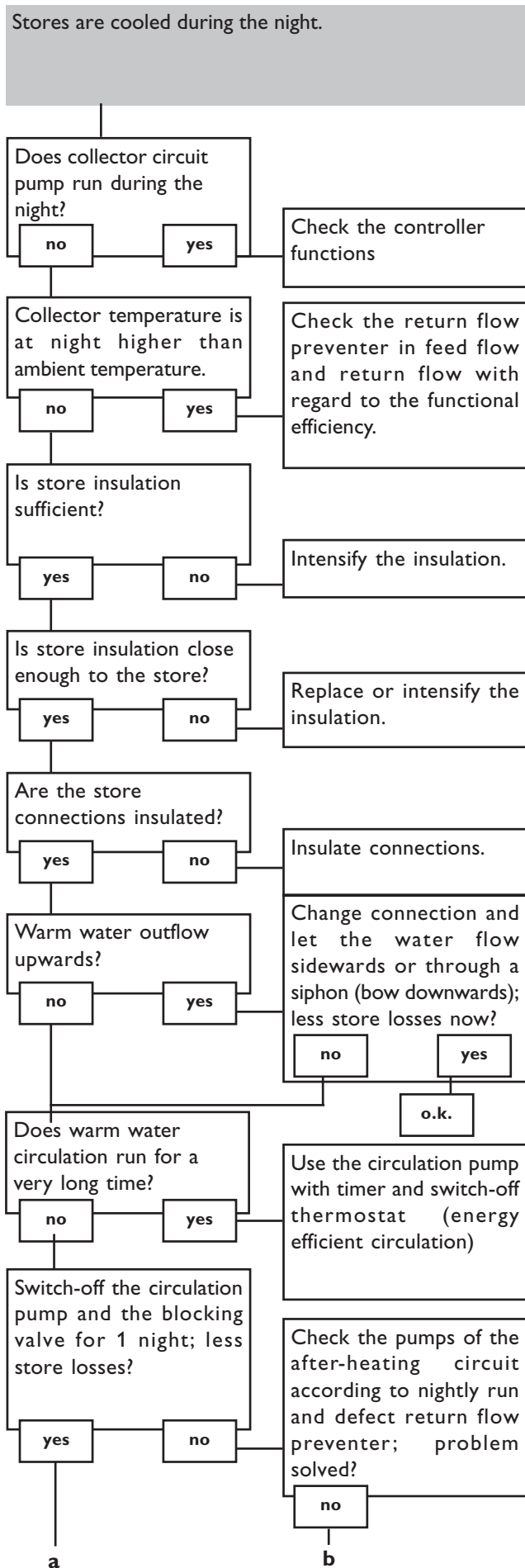

6. Accessory

Sensors

Our product range includes high-precision platinum temperature sensors, flatscrew sensors, ambient temperature sensors, indoor temperature sensors, cylindrical clip-on sensors and irradiation sensors, also to be used as full sensors with sensor pocket.



Overvoltage protection

We highly recommend to install the RESOL overvoltage protection in order to avoid overvoltage damages at the collector (e.g. by lightning).



Flowmeter

If you are interested in realising a heat quantity balancing, you need a flowmeter for measuring the volume flow in your system.



RESOL - Elektronische Regelungen GmbH

Heiskampstraße 10
D - 45527 Hattingen

Tel.: +49 (0) 23 24 / 96 48 - 0
Fax: +49 (0) 23 24 / 96 48 - 55

www.resol.de
info@resol.de

Your specialist dealer:

Please note:

The design and the specifications are to be changed without notice.
The illustrations may differ from original product.